



2023v8.0 Hub Spoke Offset, Pitch Circle Diameter and Spoke Seat Offset for KOM Xeno Hubs

This document contains wheel building information for KOM Xeno hubs. (All versions of Xeno hub feature straight pull spokes.)

This information can be input into STRAIGHT PULL spoke length calculators with various additional data (for example data from the rim of your choice) to calculate the length of spokes required.

Kom Hub Type	Spoke PCD Left & Right	Spoke Offset Left & Right	Flange Offset Left	Flange Offset Right	Spoke Cross Pattern
Xeno Front 100mm 32 Spoke	46mm	0.5mm	23.5mm	34mm	3 Cross
Xeno Front 100mm 28 Spoke	46mm	0.5mm	23.5mm	34mm	3 Cross
Xeno Front 100mm 24 Spoke	46mm	0.5mm	23.5mm	34mm	2 Cross
Xeno Front Boost 110mm 32 Spoke	46mm	0.5mm	28.5mm	39mm	3 Cross
Xeno Front Boost 110mm 28 Spoke	46mm	0.5mm	28.5mm	39mm	3 Cross
Xeno Rear 135/142mm 28 Spoke ROAD*	46mm	0.5mm	27.5mm	18.5mm	3 Cross
Xeno Rear 135/142mm 24 Spoke ROAD*	46mm	0.5mm	27.5mm	18.5mm	2 Cross
Xeno Rear 135/142mm 32 Spoke MTB**	46mm	0.5mm	27.5mm	20.5mm	3 Cross
Xeno Rear 135/142mm 28 Spoke MTB**	46mm	0.5mm	27.5mm	20.5mm	3 Cross
Xeno Rear 135/142mm 32 Spoke JUMP***	46mm	0.5mm	27.5mm	26.5mm	3 Cross
Xeno Rear 135/142mm 28 Spoke JUMP***	46mm	0.5mm	27.5mm	26.5mm	3 Cross
Xeno Rear Boost 148mm 32 Spoke MTB****	46mm	0.5mm	30.5mm	23.5mm	3 Cross
Xeno Rear Boost 148mm 28 Spoke MTB****	46mm	0.5mm	30.5mm	23.5mm	3 Cross
Xeno Rear Super Boost 157mm 32 Spoke MTB <sup>1</sup>	46mm	0.5mm	35mm	28mm	3 Cross
Xeno Rear Super Boost 157mm 28 Spoke MTB <sup>1</sup>	46mm	0.5mm	35mm	28mm	3 Cross
Xeno Rear Downhill 157mm 32 Spoke MTB <sup>2</sup>	46mm	0.5mm	35mm	34mm	3 Cross

The hub dimensions table (previous page) are intended for use with an online STRAIGHT PULL spoke length calculator. (eg: [DT Swiss Spoke Length Calculator](#)) In addition, wheel rim data will also be required.

Additional information and diagrams explaining the data above are shown in the following pages. (\* and <sup>1-2</sup> superscript denote the diagram appropriate to the rear hub type. See pages 3 and 4.)

Spoke offset (from hub centre line) is shown in the diagram below. It is shown in a positive direction. I.e., the positive offset makes the required spoke slightly longer than if the offsets in the hub were zero.

Spoke Hole Diameter 2.5mm.

The Pitch Circle Diameter (**PCD**) is the diameter of a circle which passes through the centre of all spoke holes.

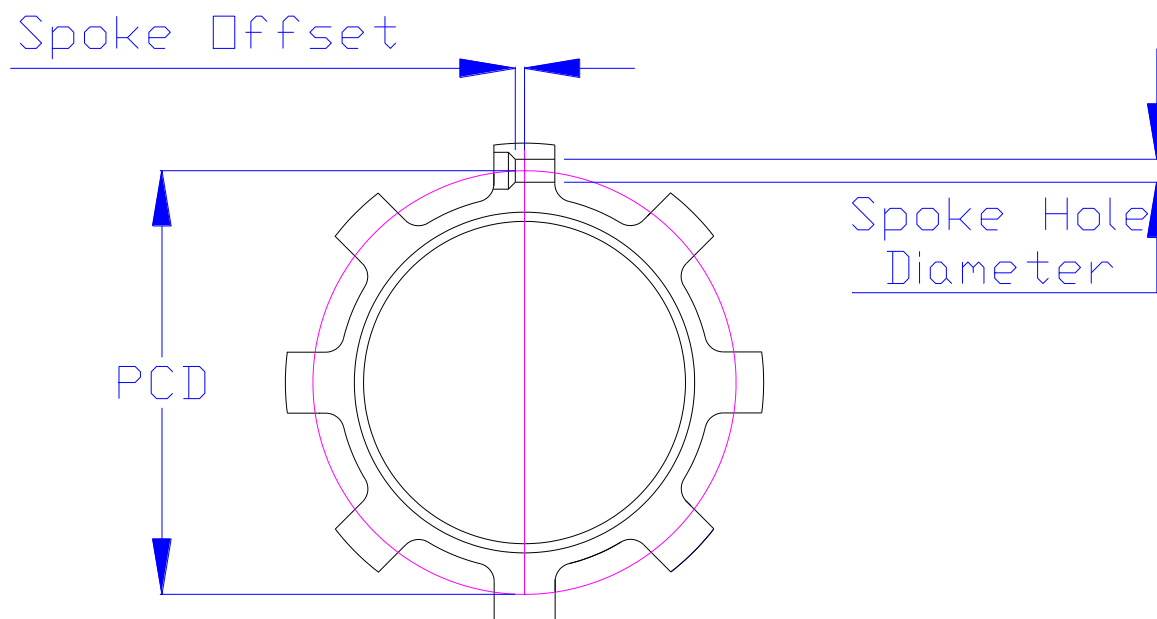

**Figure 1: Showing Spoke Hole Diameter, Spoke Offset and Pitch Circle Diameter (PCD)**

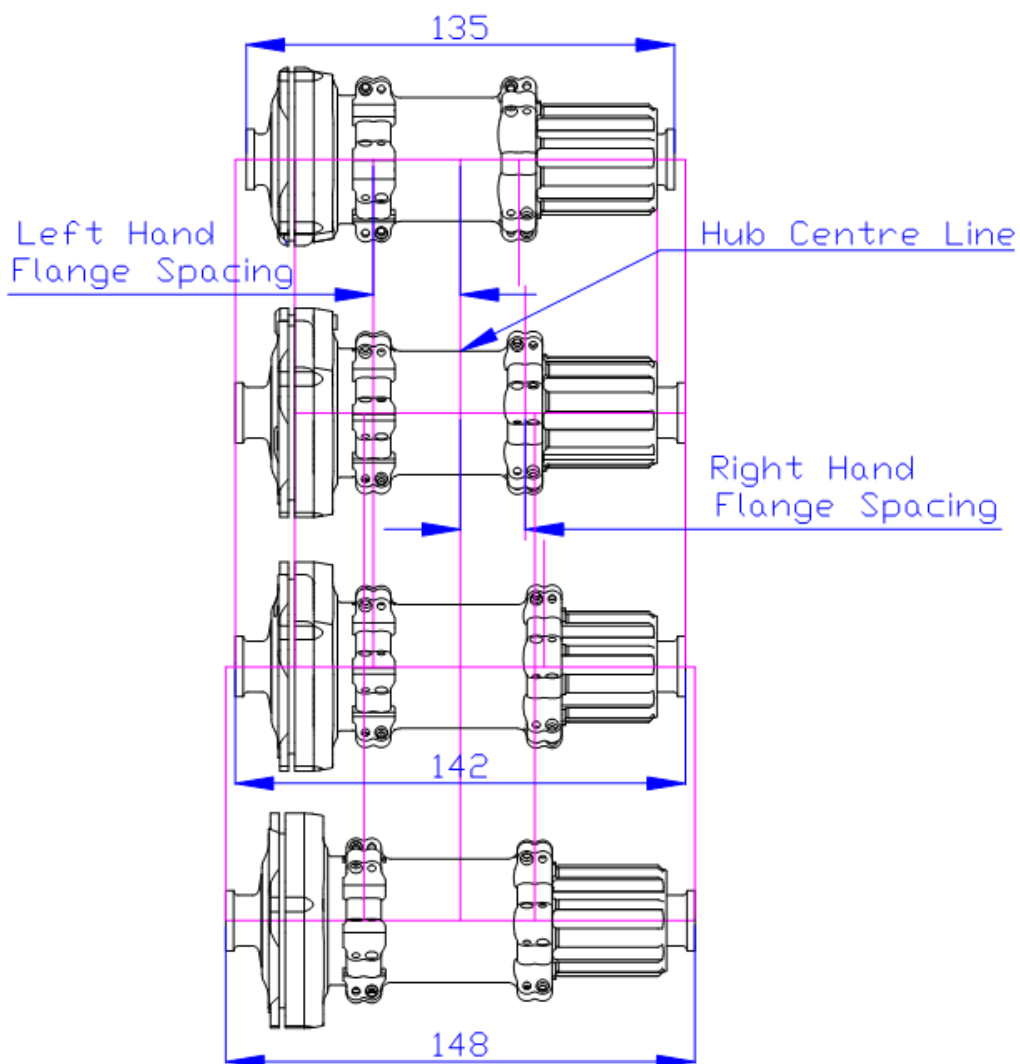

\* Top: Road variant. Shown with a Shimano HG 11 speed cassette holder. (1.8mm wider cassette holder than mountain bike variants shown below. Could also be fitted with a SRAM XD<sup>r</sup> cassette holder.)

\*\* Mountain Bike Standard variant. 142mm \* 12mm. Shown with a Shimano HG mountain bike cassette holder. (Could also be used with SRAM XD or Shimano Micro Spline cassette holder.) This hub has improved, cassette side, spoke geometry over the road variant for greater lateral wheel strength.

\*\*\* Jump, or Trials Bike shown with a thinner Shimano HG cassette type suitable for single speed or reduced width cassette. This hub has near perfect spoke symmetry for maximum, even, lateral and radial strength. (6mm narrower cassette holder than mountain bike standard.)

\*\*\*\* Mountain Bike Boost variant. 148 \* 12mm. Shown with a Shimano HG mountain bike cassette holder. (Could also be used with SRAM XD or Shimano Micro Spline cassette holder.) Improved spoke geometry over Standard Mountain Bike variant, for greater lateral wheel strength.

**Figure 2: Illustrating Road, Mountain Bike Standard, Jump Bike and Mountain Bike Boost versions of KOM Xeno Hubs and different length cassette holder options. Hubs aligned with all hub CENTRE lines.**

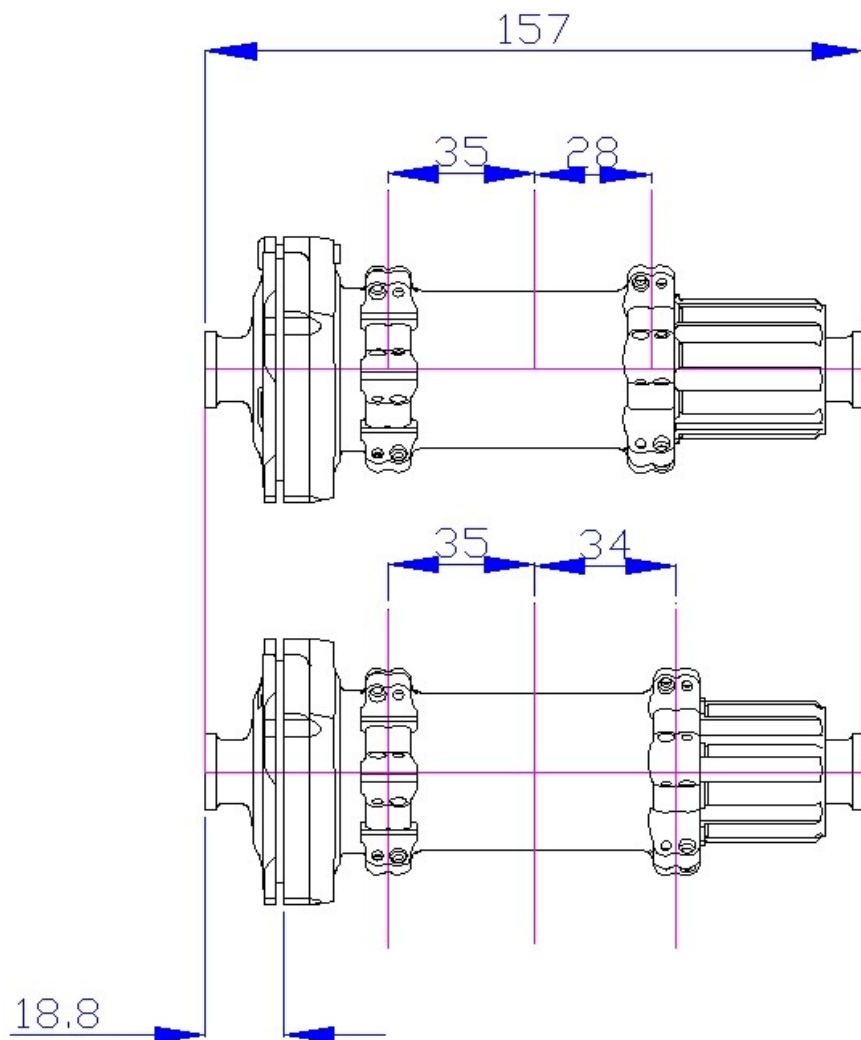

1 Top: Super Boost Mountain Bike variant. 157 \* 12mm. Shown with a Shimano HG mountain bike cassette holder. (Could also be used with SRAM XD or Shimano Micro Spline cassette holder.) This hub has a super wide spoke geometry with the spoke flanges 9mm wider than Boost Mountain Bike variant. This gives even greater lateral wheel strength than the Boost variant.

2 Bottom: Down Hill Mountain Bike variant. 157 \* 12mm. Shown with a thinner Shimano HG cassette type suitable for single speed or reduced width cassette. This hub has near perfect spoke symmetry for maximum, even, lateral and radial strength. (6mm narrower cassette holder than mountain bike standard.)

**Figure 3: Illustrating Super Boost and Down Hill Mountain versions of KOM Xeno Hubs with different length cassette holder options. The hubs are both 157mm width but, with the shorter cassette holder, the hub flanges on the Down Hill variant are wider and more symmetrically spaced.**

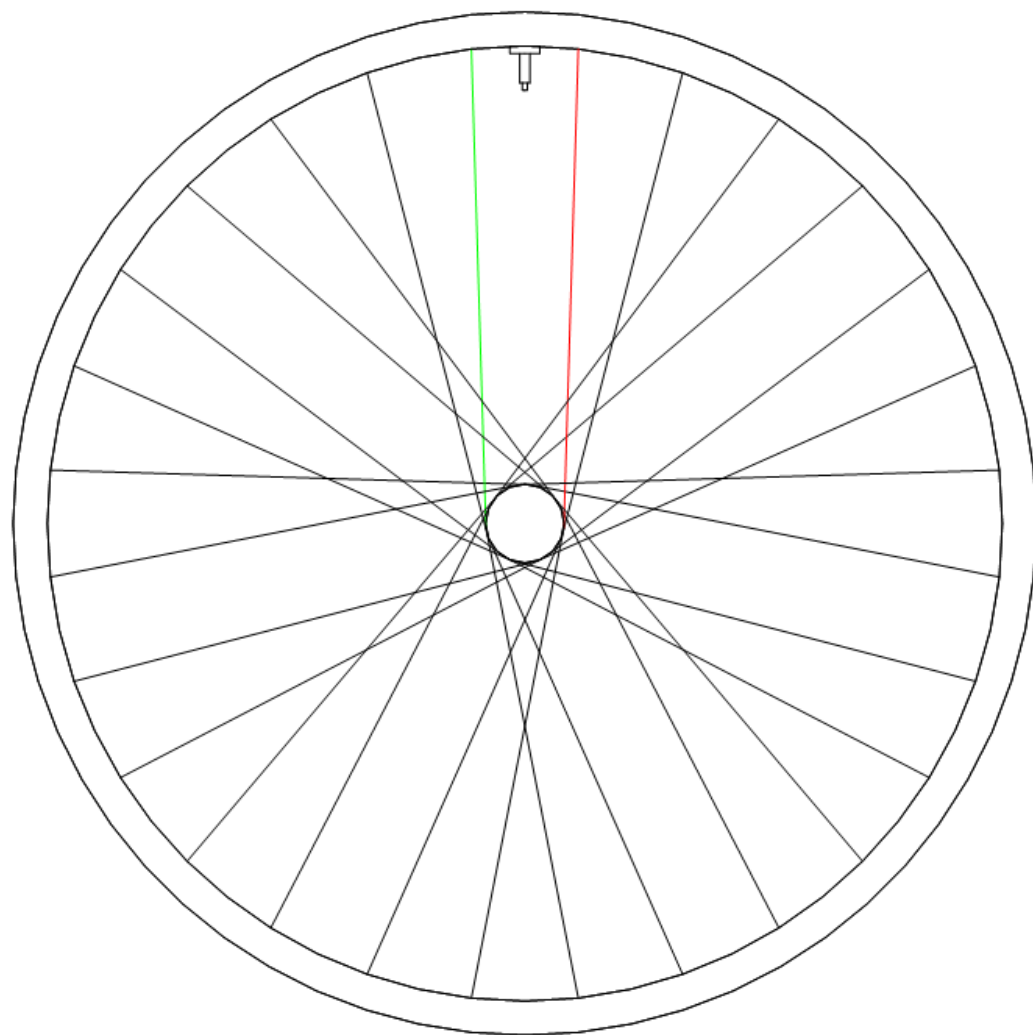

In the diagram the red spoke attaches to the far side of the hub and the green spoke to the near side.

The hub design and geometry of a straight pull hub dictates the lacing pattern because when the spokes are laced through the holes in the hub, they direct the spoke in a given direction towards the rim. This makes lacing the spokes into the rim relatively straight forwards especially if all the spokes are inserted into the hub before any are laced into the rim. In this way it is easy to see in which direction they all face and thus, which parallel spokes should be orientated next to the valve.

However, less 'obvious' is that the lacing pattern of the hub also dictates the direction of spokes either side of the valve hole. That is assuming the wheel builder intends to place the valve between the near parallel spokes, as in the diagram. (This is to make attachment of the pump, over the valve, easier.)

In the diagram the lacing of a 28 spoke rim is shown. (All 28 spokes, from both sides of the wheel, are shown which is why there appears to be more than 3 crosses per spoke.) The hub is arranged so that the KOM logo on the hub is directly below the valve. The valve, in turn is positioned between the red and green spokes which appear almost parallel when viewed from the side of the wheel. In the diagram the red spoke attaches to the far side spoke flange of the hub and the green spoke to the near side.

**Figure 4:** Shows wheel with spokes laced either side of valve hole. Red spoke attaches to far side of hub and green spoke to near side.

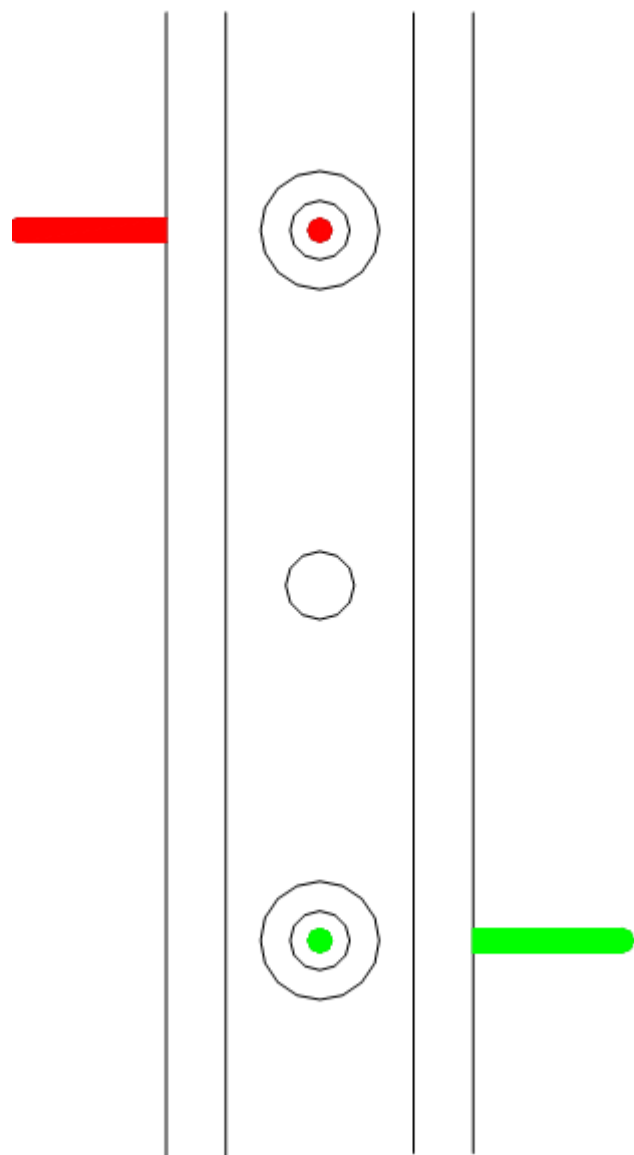

Many wheel rims are drilled such that the spoke holes are just drilled straight through the rim towards the centre of the wheel with no bias to one side or the other. Drilling rims with slightly angled spoke holes is more complicated, during manufacture, but allows the spoke nipple to sit more easily in its given orientation pointing the spoke towards the correct side of the hub. It is for this reason that more expensive wheel rims often have spoke holes drilled pointing, alternately, to one side of the hub and then the other.

When a wheel rim is drilled with alternate spoke holes orientated slightly to one side and the other there are effectively two choices of where to place the valve hole. When looked at from directly above the wheel, looking down at the valve hole, the hub end of the spokes appear to be pointing anti clockwise, as shown in the diagram (left). (If the valve hole was moved to between the next pair of spoke holes, then, the hub end of the spokes would appear to be pointing clockwise.)

This anti clockwise pointing of the spokes around the valve hole is that chosen by many rim manufacturers, for example DT Swiss, Santa Cruz etc. The same orientation is chosen for KOM Xeno hubs so that they match precisely with these rims and allow the wheel to be laced with parallel spokes either side of the valve hole.

Most wheel rims are drilled either with no alternating bias or in the manner shown in the diagram. If you have a wheel rim drilled in the opposite orientation then it would be necessary to move the rim such that the valve appeared in the next space next to a parallel set of spokes. Attempting to lace a rim with the opposite direction of spokes whilst retaining the parallel spokes either side of the valve is impossible to do, whilst still giving a good, even, wheel build.

**Figure 5:** Shows the view when looking directly down on a wheel from outside the rim with the valve hole in the centre. (If it was included in the drawing, the hub could be viewed directly below the valve hole.) The spokes appear to be pointing anticlockwise towards their respective sides of the hub.